



S4 Wood Assembly Manual

INTRODUCTION

We have all experienced the frustrations caused by incomprehensible Assembly Instructions. For this reason, we have gone to added lengths to make our instructions as clear and concise as possible. Do not be intimidated by the detail; it is simply intended to make the assembly process as comfortable as possible for you.

Your WaterRower comes partially dis-assembled in two boxes for protection during shipment.

Assembling your WaterRower should take no more than half an hour, all you require is a 5mm Allen Key which is attached to the Rear Spacer.

STEP ONE

Lay the Rails on the floor and connect the Rear Spacer using the male JCN Nuts and the Allen Key provided.

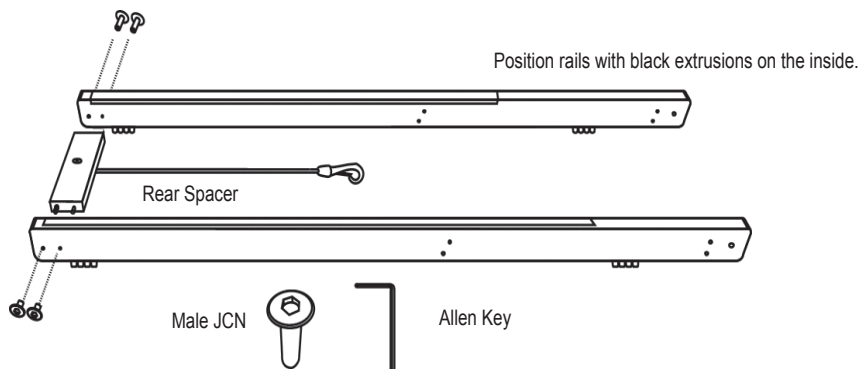

STEP TWO

Sit the Seat between the Rails. Note the orientation of the Seat with the indent facing the rear. It may be necessary to separate the Rails slightly to allow the seat to sit into place.

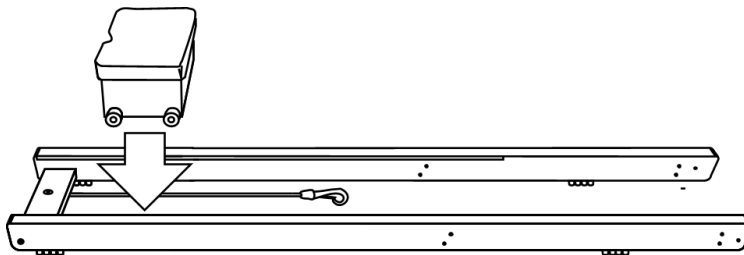

STEP THREE

Place the Tank Assembly between the Rails.

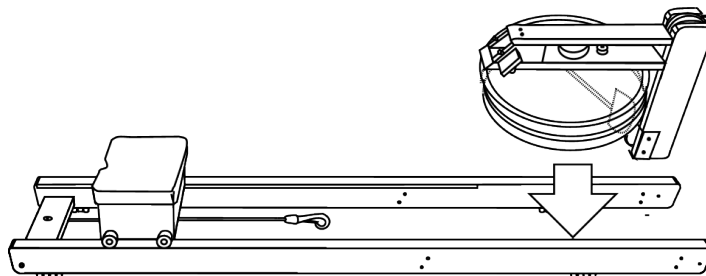

STEP FOUR

Place the Footboard between the Rails positioning the top two holes over the two threaded holes in the back Tank Unit. Screw the Handle Rests into position using the Handle Rest Bolts. It may be necessary to slightly loosen the two bolts on the Top Deck (A) to allow the Footboard clearance.

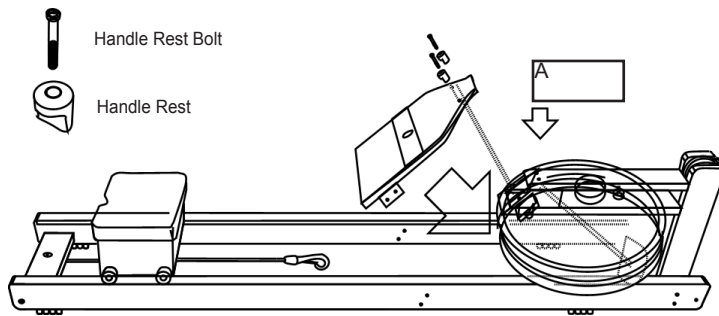

STEP FIVE

Insert the JCN Nuts and JCB Bolts attaching the Tank and the Footboard to the Rails at A & B. The Nuts should be placed on the inside and the Bolts on the outside. Should you experience any problem with aligning the components, loosen all the fasteners, align and re-tighten.

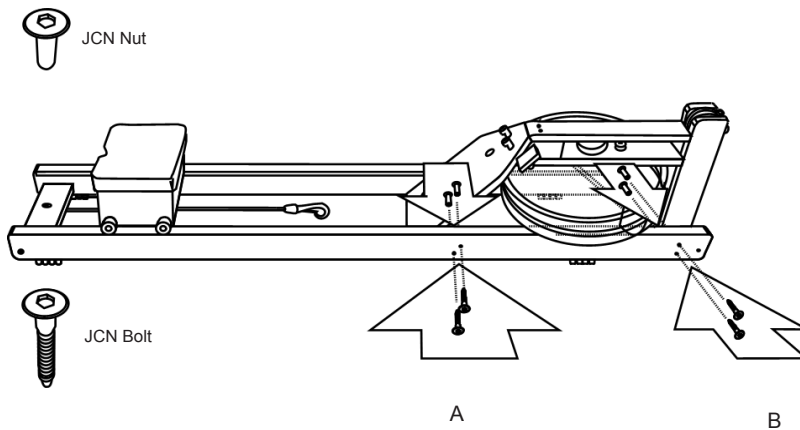

STEP SIX

Press the Heelrest Adjustment Button (A) and insert the Heelrest/Footpads into the Footboard Cover Plate (B).

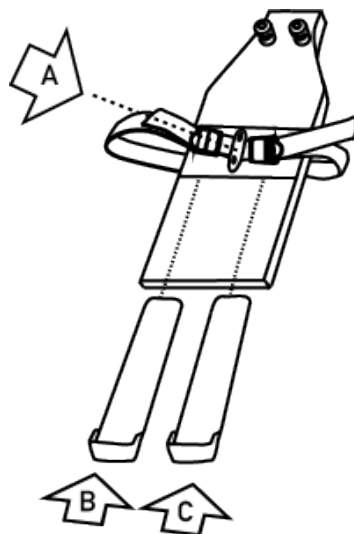

STEP SEVEN

Undo the Dolley Wheel Assembly and fix to the Rail in the order shown and tighten. Note - the Wheel goes on the outside of the Rail.

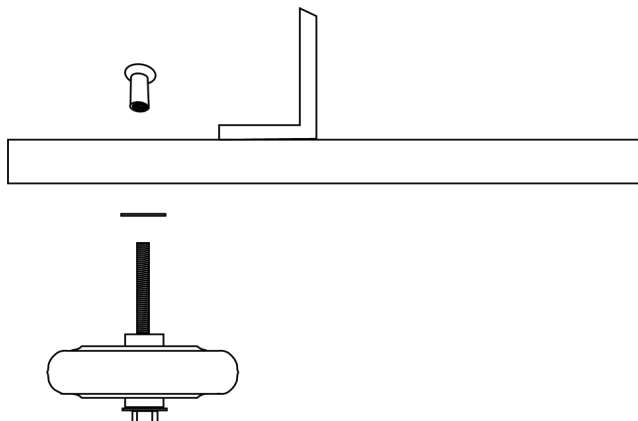

STEP EIGHT

Stand the WaterRower upright. Release the Recoil Belt which is fastened to the bracket at the base of the machine. Ensure that the Recoil Belt is passing over all Guide Pulleys. Connect the Bungee to the Recoil Strap by hooking the Bungee Hook through the Recoil Belt D-ring.

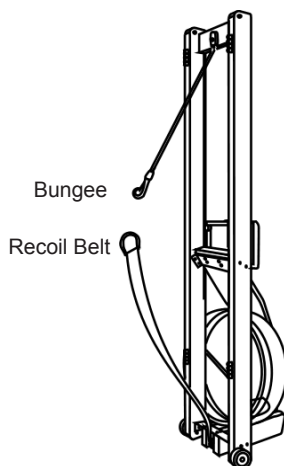

STEP NINE

Before filling the Tank and rowing ensure that the Recoil Belt passes smoothly over all Rollers.

STEP TEN

Lay the WaterRower down and using the Syphon Pump provided (or a hose if available) fill the Tank to the desired level (See Water Level section in the Owner's Manual) with Chlorinated Town or Municipal Water. Do not over fill your WaterRower. Anything more than half full (or above the bottom edge of the Paddle Shaft when the machine is standing) may risk leaking. Insert the Stopper (it may be necessary to moisten the Stopper to assist replacement). Congratulations, your WaterRower is now ready for use.

